



EN

Operating Instructions

Caution:

Before starting, please read and note the operating and safety instructions

Operating and safety instructions for Hulco trailers

Content:		
1.	Introduction	2
2.	Trailer (general)	3
3.	Electrical connection of the lighting system	3
4.	Wheel and tyre	5
5.	Jockey wheel	5
6.	Wheel stops	7
7.	Opening and closing of the side boards	8
8.	Pull out beams	8
9.	Charging of the trailer	8
10.	Spare parts	9
11.	Tipping trailers	10

1. Introduction

Dear customer,

Congratulations with your Hulco trailer. We would like to draw your attention to the following important information.

What to do before using the trailer:

Before you take the combination car and trailer onto the public roads, it is absolutely necessary for safety reasons that you become thoroughly familiar with the operation of your Hulco trailer.



- **Read these general instructions carefully.**
- **Also read the documents that apply to the components such as; clutch, handbrake and axles.**

You will find all the above mentioned (PDF) documents at: www.hulco.eu.

If you have any questions or if anything is unclear in this manual, please contact your Hulco dealer. Also for maintenance and sales of accessories, for example, you can contact him.

Disclaimer: The illustrations in this manual may differ from the actual product. Where left, right, front and/or rear, you are, as it were, standing behind the trailer.

2. Trailer (general)

- No welding is permitted on the hot galvalised parts. Other materials (like aluminium and cables) could be influence, hereby there is a change on lasting damaging or remodelling.
- There is a permit allowing the trailer to be used on roads in your country. This means that the vehicle has been formally offered to the inspection authority in your country for approval when your trailer was manufactured in our factory. Any modification (e.g. different lighting, rims/tires or coupling or adding an accessory that is not from the Hulco factory and that changes the dimensions and masses) is not allowed.

Maintenance and cleaning of hot-dip galvanised parts of the vehicle:

- The formation of white rust is only a cosmetic fault. The following measures may be taken to avoid this to the extent possible:
 - Ensure that there is sufficient air circulation when parking and in connection with the storage of hot-dip galvanised components.
 - After driving in winter, the hot-dip galvanised surfaces may be cleaned with clean water in connection with salt/brine (for example using steam jets).
- For the safety instructions, operation, maintenance and cleaning of trailer component, please refer to items further discussed below, which apply to your trailer.
- Check whether driving with the trailer is officially allowed. Can the towing vehicle drive with the trailer, and does your driving licence permit you to drive the combination?
- Ensure conformity with the applicable laws relating to what the load may or may not consist of (such as hazardous substances and passengers).

3. Electrical connection of the lighting system

When coupling the trailer, the proper working of the lighting system should be checked after inserting the plug into the vehicle plug. If the working is not satisfactory, the cause of the problem should first be identified and repaired before the combination is driven on public roads.

Your trailer is equipped with a 13-pole plug as per ISO 11446. If the towing vehicle is not equipped with a plug socket of this type (but is equipped with a 7-pole plug as per ISO 1724 for example), the lighting will not work properly. This can be remedied by using an adapter for connecting a 7-pole vehicle plug socket to a 13-pole trailer plug.

These adapters are commercially available. This adapter will be placed between the plug of the towing vehicle and the plug of the trailer. You may check whether the towing vehicle is equipped with the same type (13-pole) of plug in the following manner:

- If the words "ISO 11446" appear on the plug, it means it is a 13-pole plug; if the words "ISO 1724" appear, it means it is a 7-pole plug.
- Please enquire with the supplier of the towing vehicle.

No extra lighting fixtures need be added.

When replacing (incandescent) lamps, it should be ensured that the replacement (incandescent) lamp is in accordance with (12V/5W – 12V/21W).

For this, check the information appearing on the replacement (incandescent) lamp.

The trailer is permitted for use on the road in your country. This means that the vehicle has been offered for inspection to the authority responsible for the same, as soon as your trailer is manufactured in our factory, and therefore fulfils the applicable permit requirements. No modifications or additions may be made to the same (extra lighting and the addition of for example, "lighting safety grills").

After coupling, the 13-pole plug of the trailer should be immediately inserted in the plug of the towing vehicle. This is only possible in one way.

The plug connection is as follows (with, in sequence, the connection number / code, colour of the wiring and function):

Pin	Function	Colour
1 / L	Left turn indicator	Yellow
2 / 54G	Fog lamp	Blue
3 / 31	Ground	White
4 / R	Right turn indicator	Green
5 / 58R	Rear lamp, right	Brown
6 / 54	Braking light, left and right	Red
7 / 58L	Rear lamp, left	Black
8	Reversing lights	Grey
9	Constant current	Brown/Blue
10	Ignition switched current	Brown/Red
11	Ground (pin 10)	White / Red
12	Trailer recognition	Pale grey
13	Ground (for pin 9)	White / Black

Note: Hulco uses poles 1 to 8. of the 13-pole plug (Fig. 1 B).

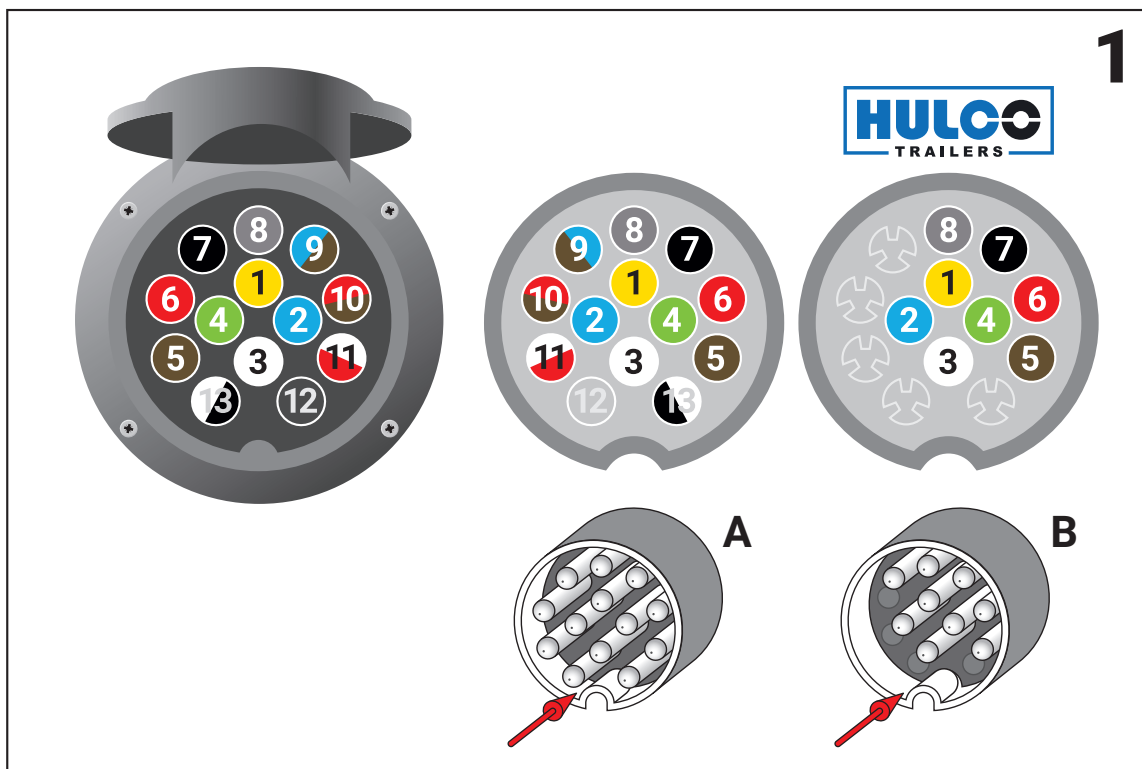

4. Wheel and tyre

Ensure that the tyres are at the correct tyre pressure and have an adequate tyre tread (as regards safety and uniformity of wear-and-tear). The tyre pressure should be applied in the "cold" condition with the vehicle in an unloaded condition.

Tyre	Use with axle load	Tyre Pressure		
		bar	psi	kPA
185/70 R13	1200 - 1300 kg	3,4	50	340
145 R13 145/80 R13 155 R13 155/80 R13	750 kg	2,8	41	280
155/80 R13	1000 kg	2,9	42	290
195/70 R14	1350 kg	3,4	50	340
185 R14	1400 kg	4,5	65	450
195/55 R10	1500 - 1750 kg	6,25	90	625
195/50 R13	1500 - 1750 kg	6,5	95	650
185/60 R12	1500 - 1750 kg	6,5	95	650

ATTENTION: You cannot ensure that your tyres have a minimum pressure of 6.25 bars in all places. If tyres have a tyre pressure less the values mentioned in the table, there is a chance of punctures. The tyre pressure should be checked regularly. For information about the minimum tyre tread, please abide by the applicable regulations.

The following applies to a new trailer: **After 50 km, tension the wheel nuts with a suitable tool.** This should be done with a tightening torque of 90-120 Nm. If a trailer is regularly used, it should also be regularly checked later on.

5. Jockey wheel

The jockey wheel is for coupling, uncoupling and shunting of the trailer.

Ensure that the maximum permissible coupling pressure is not exceeded through the loading of the trailer. At this load, where the jockey wheel is used, a permissible load of the jockey wheel will arise.

Operation of the nose wheel version (Fig. 2)

Uncoupling unbraked trailers with nose wheel Fig. 2

By loosening the clamping lever (Fig.2 No.1), open the nose wheel holder, lower the nose wheel as far as possible and tighten the clamping lever (fig. 2 no. 1) again. Disconnect the auxiliary coupling and lighting plug from the towing vehicle. Use the wheel chocks for the unbraked trailer. Use wheel chocks for the unbraked trailer. Open the ball coupling and at the same time turn the crank (Fig. 2 No. 2) to the left to rotate the nose wheel outwards until the coupling of the trailer hitch is released. until the coupling has been released from the drawbar ball of the towing vehicle.

Coupling of unbraked trailer Fig.2:

- Coupling is carried out in reverse order:
- Turn the nose wheel up until the wheel flanges are fixed in the recess of the outer pipe (Fig. 2 No. 3). are secured Tighten the clamping lever (Fig. 2 No. 1) firmly. This secures the nose wheel against unintentional The front landing wheel is thus secured against unintentional turning during travel.
- Pull the nose wheel up as far as possible through the clamping lever. Let the wheel run approximately parallel to the drawbar. parallel to the drawbar.
- Tighten the clamping lever (Fig. 2 No. 1) so that the front landing gear is secured against sliding down.

Uncoupling a braked trailer Fig. 2:

- Uncoupling cable and lighting plug from the towing vehicle. Apply the handbrake of the trailer.
- By loosening the clamping lever (Fig. 2 No. 1), open the nose wheel support, lower the nose wheel as far as possible and lower the nose wheel as far as possible and retighten the clamping lever (Fig.2 No.1).
- Open the ball coupling and at the same time turn the crank (Fig. 2 No. 2) to the left to rotate the nose wheel out until the ball coupling of the trailer is engaged. Turn the nose wheel outwards until the coupling has been released from the tow ball of the base vehicle.

Coupling the braked trailer Fig.2:

- Coupling is carried out in reverse order:
- Turn the nose wheel up until the wheel flanges are fixed in the recess of the outer pipe (Fig.2 No. 3). Tighten the clamping lever (Fig. 2 No. 1) firmly. This secures the nose wheel against unintentional turning. The front landing wheel is thus secured against unintentional turning during travel.
- Pull the nose wheel up as far as possible through the clamping lever. Let the wheel run approximately parallel to the drawbar.
- Tighten the clamping lever (Fig. 2 No. 1) so that the front landing gear is secured against sliding down.
- Fasten the breakaway cable and lighting plug of the base vehicle. Release the handbrake of the trailer.

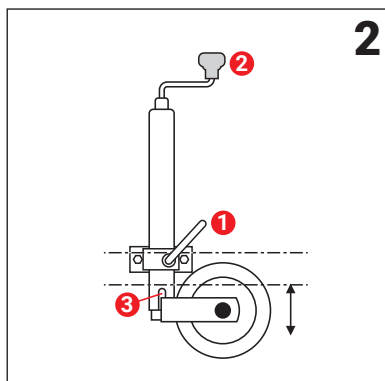

Operating the nose wheel of braked trailers (Fig.3)

Uncoupling an unbraked trailer Fig.3:

- Before uncoupling the trailer from the towing vehicle, the nose wheel must be turned out. By turning the crank anti-clockwise, the nose wheel first unfolds (Fig. 3 No. 1). When this is completed, the wedge (Fig. 3 No. 2) reaches its end position and the front landing wheel swings out.
- Open the ball coupling and turn the nose wheel to the desired height by which the coupling will be above the tow ball.

Please note! When the trailer is uncoupled, the front landing wheel is under load (Fig. 4 No. 3). Therefore, never turn the nose wheel so far that the folding mechanism is actuated!

Coupling the unbraked trailer Fig.3:

- Coupling is done in reverse order:
- After coupling, the nose wheel must be turned fully up again. Make sure that the folding wedge (Fig.3 No.2) touches the collar (Fig.3 No.4) of the nose wheel and, by turning the crank further to the right, moves over the collar of the nose wheel. Turn the crank further to the right and it will move over the collar of the nose wheel. The nose wheel will then swing up automatically.

Operating the nose wheel of braked trailers (Fig.3)

Uncoupling an unbraked trailer Fig.3:

- Before uncoupling the trailer from the towing vehicle, the nose wheel must be turned out. By turning the crank anti-clockwise, the nose wheel first unfolds (Fig. 3 No. 1). When this is completed, the wedge (Fig. 3 No. 2) reaches its end position and the front landing wheel swings out.
- Open the ball coupling and turn the nose wheel to the desired height by which the coupling will be above the tow ball.

Please note! When the trailer is uncoupled, the front landing wheel is under load (Fig. 4 No. 3). Therefore, never turn the nose wheel so far that the folding mechanism is actuated!

Coupling the unbraked trailer Fig.3:

- Coupling is done in reverse order:
- After coupling, the nose wheel must be turned fully up again. Make sure that the folding wedge (Fig.3 No.2) touches the collar (Fig.3 No.4) of the nose wheel and, by turning the crank further to the right, moves over the collar of the nose wheel. Turn the crank further to the right and it will move over the collar of the nose wheel. The nose wheel will then swing up automatically.

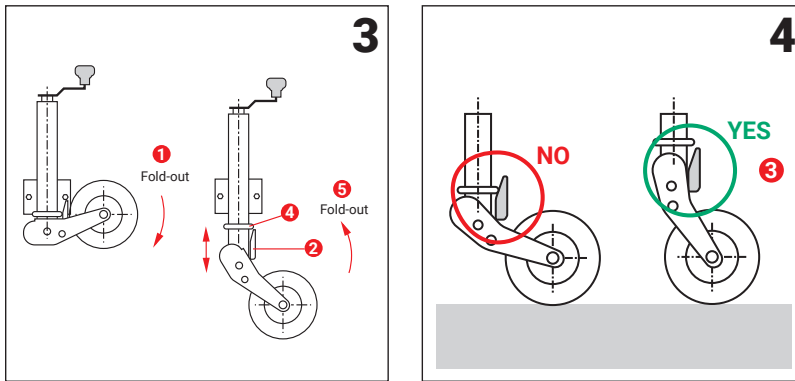

When rotating the nose wheel, make sure that the brake rod of the trailer remains free of any part of the nose wheel. If the brake rod comes into contact with the trailer, optimum braking is no longer possible.

The following applies for both types of nose wheel: Regularly clean and lubricate the moving parts.

6. Wheel stops

Use the wheel stops to uncouple the trailer. This will prevent the trailer from moving.

In the braked version, use the hand brake of the trailer in addition to the wheel stops.

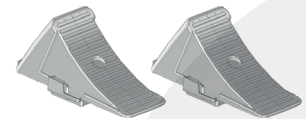

Before placing the wheel stops, check the condition of the base surface on which the wheel stop will be placed. This should be sufficiently sturdy.

Before uncoupling the trailer, first place the wheel stops (depending on the slope of the base surface) in front or behind the tyres (the right and left tyre). In case of tandem axle versions, select the front or back axle.

Before coupling the trailer once again, you should also actually first uncouple and then remove the wheel stops on the tyres and store them away in the holder installed on your trailer for this purpose.

7. Opening and closing of the side boards

When opening and closing the side boards, ensure that persons present near the boards are not exposed to danger, or risk getting entrapped, or injured in any other manner whatsoever.

While opening the tailboards on public roads, the applicable laws should be duly followed. If the applicable laws require this, use the pull-out beams present in the trailer. When the tailboard is resting on the pull-out beams, the lighting fittings remain visible.

ATTENTION: *Ensure that you are visible during loading/unloading on public roads. This is for your safety and that of other road users.*

NEVER ride with the opened sides.

Ensure regular lubrication of the lock mechanism. This can be done from the top using a Teflon or silicone spray.

8. Pull out beams

The lock for the pull-out beam is placed behind the lighting box. The pull-out beam is unlocked on pulling down the lock, and can be pushed out backwards. The tailboard can thereby be laid horizontally on the pull-out beams. The lighting and reflectors will therefore remain visible during loading and unloading.

ATTENTION: *During loading and unloading on public roads always place the pull-out beams around the tailboard. Ensure that you are visible during loading/unloading on public roads. This is for your safety and that of other road users.*

9. Charging of the trailer

- The cargo should be properly secured in place. This is to prevent loss and shifting of the cargo during motion. The shifting of the cargo may lead to a sudden change in the handling characteristics of the vehicles.
- Before driving, always check all the tension locks to see if they are properly and fully closed. This is to prevent loss and displacement of cargo and/or components.
- Furthermore, while loading the vehicle on public roads, follow all the applicable regulations (among others, the visibility of the lighting and maximum length of projecting cargo).
- Check whether it is permissible to drive with the trailer.
 - Does the towing vehicle allow driving with the trailer?
 - Is the combination in accordance with your Driving Licence?
- It is preferable to load and unload your trailer when coupled and always in a horizontal, flat position. If this is not done, check whether the trailer may "topple" (the jockey wheel lifts off the ground) during loading or unloading.
- Follow the applicable laws concerning what the load may consist of (such as hazardous substances and persons).
- While loading the trailer, keep in mind the net loading capacity of the axle(s) and the coupling. Distribute the loading in such a manner over the loading floor that the correct coupling pressure is achieved. This coupling pressure should never exceed the maximum permissible level, and should also be in accordance with the possible coupling pressure for the towing vehicle. For the correct information, please contact your (towing) vehicle supplier, or check the user manual of the towing vehicle.

Please note: When loading the trailer, pay attention to the net load capacity for the axle(s) and coupling. Distribute the (Fig. 6) in such a way that a correct coupling pressure is achieved. This coupling pressure may never exceed the maximum permissible and must also be in accordance with the possible coupling pressure for the clutch pressure for the towing vehicle. Measure your coupling pressure in the laden condition (Fig. 7) on a horizontal surface. For the correct data, ask your (base) vehicle dealer or consult the operating manual of the base vehicle. the towing vehicle.

ATTENTION: The coupling pressure must never be negative, this means that the coupling pulls vertically on the tow ball of the towing vehicle (Fig.5 No. A). The minimum coupling pressure must also be in accordance with the applicable regulations. must be observed. Incorrect loading or overloading results in excessive coupling pressure (Fig.5 No.B). This must be This must be avoided at all costs,

Please note: Your trailer has been constructed, calculated and tested (by means of an endurance test) for the loads as specified in the documents accompanying your trailer and for the maximum speed applicable on public roads for a applicable to a towing vehicle with trailer. The permitted load can also be found on the The permitted load can also be found on the construction plate (or type plate) fitted to the trailer. Overloading can lead to permanent damage Overloading can result in permanent damage to any component. As the manufacturer, we cannot be held liable for this.

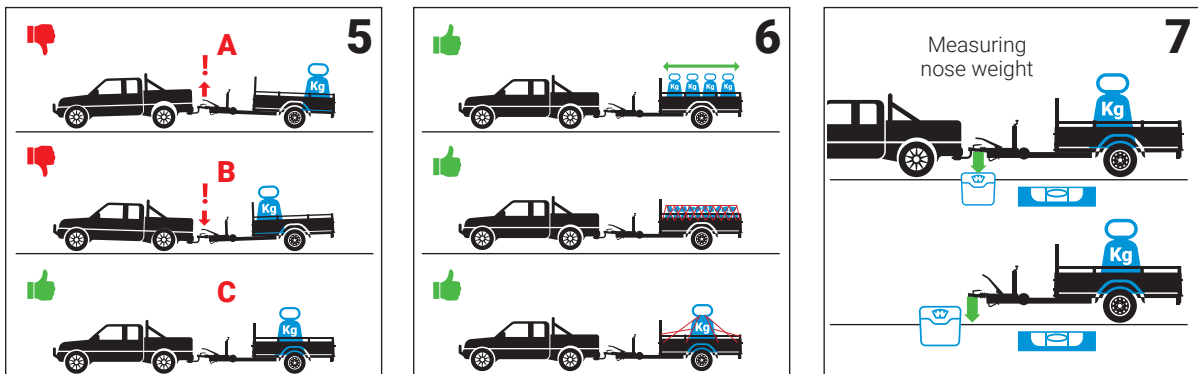

10. Spare parts

Spare parts are parts that determine safety. If other than original spare parts are used, the warranty and product liability will lapse. In this case, we as the manufacturer are not liable for any faults that may occur and for the consequences of these. Consequential damage up to and including bodily harm on public roads should not be underestimated. Please bear this in mind when using spare parts!

11. Tipping trailers

Hulco tipping trailers are three-way tipping trailers operated with an electric pump. They can also be equipped with an emergency hand pump, allowing the tipping function to work in the event of a power failure.

Three-way tipping trailers

Tippers with a three-way tipping function are equipped with a hinge point at each corner. Each hinge point has two locking pins. The positions of these locking pins determine whether tipping is possible to the rear, left, or right.

ATTENTION: *If the pins are placed "diagonally" (e.g. front left and rear right), this will cause damage.*

Sideways tipping with emergency hand pump

Unlike an electric pump, which has a limit for sideways tipping, an emergency hand pump allows you to keep pumping indefinitely and therefore continue tipping. Over-pumping and over-tipping is absolutely not intended.

ATTENTION: *During sideways tipping, the upper frame must not be tilted more than 45°. Pumping beyond this point may cause damage!*

Tipping trailers with an electric pump

For tipping trailers with an electric pump, a specific 12 V – 6/10A charger for the battery is supplied. To ensure reliable operation of the charger, a manual is included. You must carefully read this instruction manual before use and follow the technical specifications.

Use of tipping trailers

A tipping trailer is used, among other things, for transporting loads such as sand. Keep an eye on the total weight of your trailer when filling the bed (fully) with sand!

Maintenance of tipping trailers

Weekly inspection:

- Check the hinges (ball and socket) for contamination and clean if necessary.
- Ensure there is sufficient grease on the hinge. Apply grease if needed.
- For electric tippers, check the cables for the end stop (sideways tipping) and the mounting of the switch on the support.
- Check that the hydraulic hose is undamaged. No damage is allowed.

ATTENTION: *When performing maintenance with a raised tipping platform, the provided support must be used. This can be placed when the cylinder is fully extended. Then position the support under the bed and "depressurize" the cylinder. First, check that the hook on the upper frame is correctly positioned in the recess of the support.*

Annual inspection:

- The tipping trailer must be inspected at least once a year by trained personnel at authorized workshops or service centers



HULCO, FOR PROFESSIONALS WHO DEMAND PREMIUM QUALITY



The Anssems Group has a complete range of transport solutions for you with the brands Hulco and Anssems. Hulco trailers distinguish themselves by reliability and durability since 2003.



A Low loader trailers **BSX**



A Low loader trailers **GT-O**



A Low loader trailers **GT-R**



A Flatbed trailers **ASX**
(Incl. ramps)



A Flatbed trailers **PSX**



H Flatbed trailers **MEDAX**



A Flatbed trailers **PLT**



H Multipurpose trailers
CARAX



A Multipurpose trailers
MSX-Basic / MSX



A Car transporters
AMT



A Car transporters
AMT-ECO



A 3-way tipping trailers
KSX



A Backwards tipping trailers
KLT



A Hard top cover trailers
GT-HT / GT-VT1



A Box van trailers
GT-VT2 / GT-VT3 / GT-VT4



H Plant trailers
TERRAX



H Plant trailers
TERRAX-Basic



A Horse trailers **PTH**



A Welfare trailers **PTS**



Wide range of accessories